

JupiterBike

Bicycle Hunting Trailer Owner's Manual & Instructions

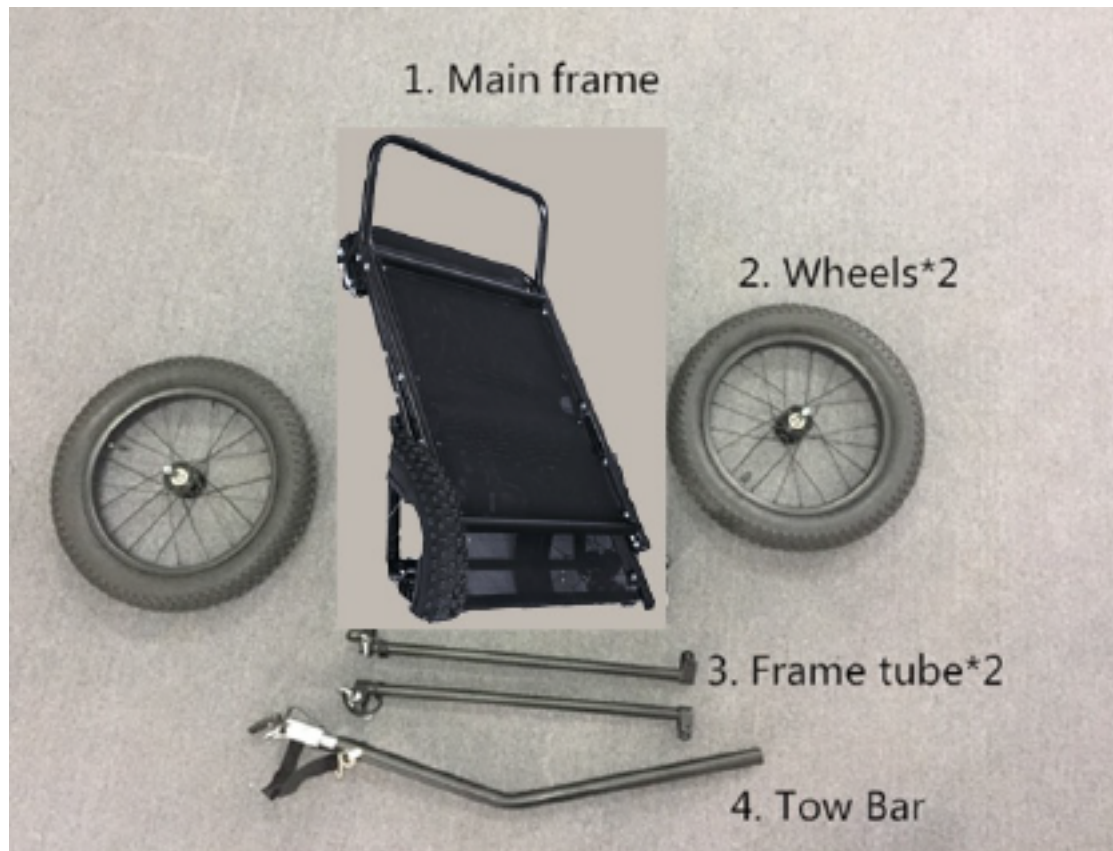

TRAILER COMPONENTS



Please read through this manual and follow instructions before and during use.

1. Installing the wheels

Insert the wheel axle to the tube in the middle of frame bottom. Make sure that the wheels are fully engaged.



2. Installing the frame tubes

Use the silver quick release to lock 2pcs frame tubes, see below pictures.



Main Frame has three holes (see below photos). The two on the side will adjust the center of gravity when loading the goods to keep the trailer's balance.

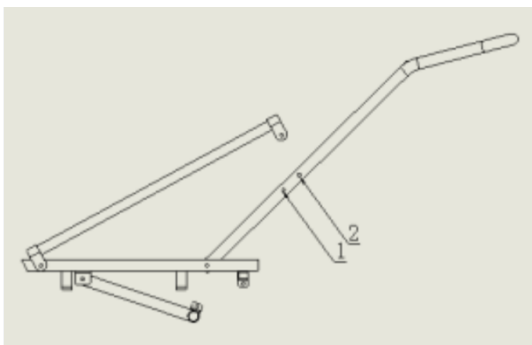

3. Fixing the tow bar

To attach the draw-bar, push the round end into the receptacle provided (figure 1) on the left hand side. Secure the inserted draw-bar with the quick-action tension jack supplied (pos. a) and the locking pin

The bend in the draw-bar is now facing right with respect to the direction of travel. Important: Ensure that the pin is securely locked, a loose draw-bar could result in losing control of the trailer while riding.

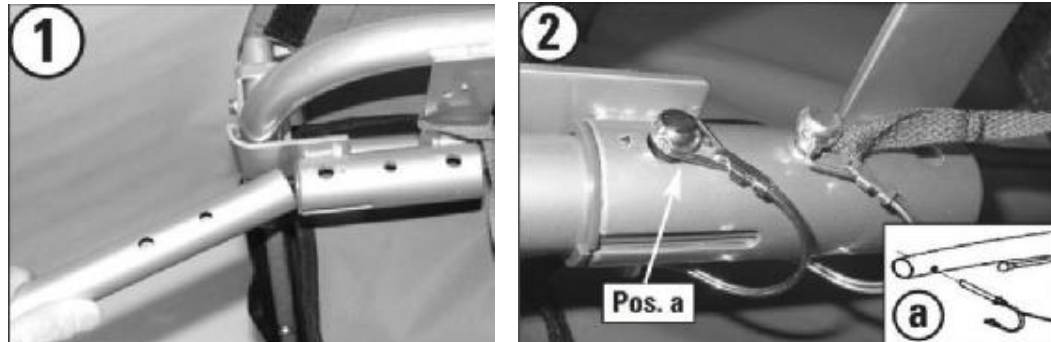

Hitching the Trailer on the Bicycle

NOTE: The universal hitch is only suitable for bicycle with full axle or a quick release axle.

1. Bicycles with Full Axle

Remove the left hand axle nut from the bicycle. Put the hitch on the axle and re-attach the nut. **WARNING:** The axle nut should be tightened on the axle by

at least 5 full turns to ensure adequate clamping force. Not fully tightening can result in accidental loosening of the rear wheel and cause serious injury or death. If in doubt, contact a specialist dealer.



2. Bicycles with Quick Release Axle

Remove the quick release from the bike and guide it through the hitch along with the quick release axle. Push the quick release through the wheel hollow axle again, screw the nut and clamp the quick release with the correct pressure.

In order to ensure that the hub is clamped sufficiently in the hollow axle, the quick release lever must begin gripping as it moves from the open to the middle position, and approaching the closed position you should clearly feel resistance as you tighten. If it is too easy or too difficult to move the quick release lever, tighten or loosen the quick release nut on the other side of the hub.

WARNING: The thread of the quick release nut must be tightened on the quick release axle by at least 5 full turns to ensure adequate clamping force. A quick release axle which is too short can result in accidental loosening of the rear wheel and cause serious injury or death. If in doubt, contact your specialist dealer. Insert the safety pin through holes in both hitch and hitch connectors. Rotate and lock up the pin. Wrap the safety strap around the chain stay and fasten it to the tow bar D-ring with the snap hook.

WARNING! Hitch and safety strap must be properly installed. Inspect the hitch and tow bar frequently for any damage or loose fasteners. Damaged or improperly installed can result in serious injury or death.

Safety Instructions:

- The trailer is intended to carry house goods only. No human passengers!
- Maximum load: 100 kgs or 200 lbs
- Maximum speed: 16km/hour. or 10 mi/hr
- Always wear a helmet when riding.
- Carefully check the bolts, nuts and safety pins. Make sure that all these parts are properly tightened or locked.
- Be aware that riding with the trailer increases your braking distance and may affect your ability to control the bicycle. Thoroughly practice in a safe area until you become familiar with it.
- Only use factory-supplied wheels, with the tires inflated to 30-35 P.S.I. Check pressure before each use.
- Do not make any alterations to the trailer or hitch, which could result in injury or death.